



# PORTLAND

Bedrooms &  
Home Office  
— Collection —

# PORTLAND

Doors: Belsay  
Textured Woodgrain Effect: Ives Blue  
Handle: Skelton T-Bar (K1115.80.PE) from the Pewter Collection



# PORTLAND

## Contents

---

### Bedroom Collection

Classic	6
Belsay	8
Chapter	14
Hunton	20
Mornington Beaded	26
Modern	32
Porter	34
Sculpt	40
Feature Doors	46
Made-to-Measure	48
Stanhope	50
Unity	58
Sliding	66
Walk-in Collection	
Internals Collection	72
YouK	76
	84

---

### Home Office Collection

Belsay	90
Crathorne	94
Hunton	98
Mornington	102
Beaded	106
Mornington Shaker	110
Porter	

---

### Finishing Touches

Painted Palette	
Outline	116
Handle Collection	120
Lighting Collection	124
	144

---

### Planning & Guidance

Hinged	
Made-to-Measure	152
Sliding	154
	156

# Bedroom

## COLLECTION

As a place to get ready on a morning, and a sanctuary to relax in at the end of a busy day, you deserve to have a bedroom you truly love spending time in; a space that seamlessly balances design and function.

From the ornate detailing of our classic Mornington Beaded range, to the distinct integrated handle of our modern Sculpt door, our bedroom collection includes an array of designs to suit both traditional and contemporary interiors.

Let us inspire you with the very latest in fitted furniture, including an extensive collection of complementary finishing touches, to bring your perfectly tailored bedroom to life.

SHOWN ON COVER:  
Doors: Belsay  
Textured Woodgrain Effect: Dove Grey  
Handle: Didsbury T-Bar (H1158.72B496MB) & Didsbury Knurled (H1140.192.MB) from the Black Collection



Doors: Hunton  
Smooth Painted Finish: Porcelain & Dry Rose  
Handle: Outline Edge with Brushed Brass backplate



Doors: Mornington Beaded  
Solid Timber: Copse Green  
Handle: Outline Edge with Brushed Brass backplate

# Classic

COLLECTION

From the ornate detail of our Mornington Beaded range, to the simply elegant Shaker style of our Belsay door, the Classic Collection re-imagines traditional aesthetics for the 21st century, with truly timeless styles that you will continue to love for years to come. Available in neutral, calming shades as standard, or in a range of unique colours as part of our extensive Painted Palette, our Classic Collection allows you to create your own vision of traditional beauty.



Belsay  
CLASSIC COLLECTION





Doors: Belsay  
Textured Woodgrain Effect: Ives Blue  
Handle: Skelton T-Bar (K1115.80.PE) & Skelton Bar Handle (H1142.128.PE) from the Pewter Collection



# Belsay

## CLASSIC COLLECTION

This simply elegant Shaker door features a frame with modern proportions, a distinctive chamfer detail and a textured woodgrain effect, perfect for creating a bedroom look that will never grow old.

*Available in three beautiful shades as standard, and our full Painted Palette.*



Feature storage units with a Didsbury T-Bar (H1158.72.MB) from the Black Collection



Didsbury Knurled (H1140.192.MB) from the Black Collection



Internal storage bundle 9 in Walnut effect

Available Finishes

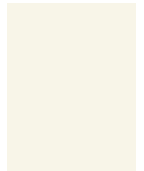

PORCELAIN

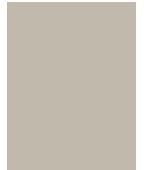

CASHMERE



DOVE GREY



Painted palette



Doors: Belsay  
Textured Woodgrain Effect: Ives Blue  
Handle: Skelton T-Bar (K1115.80.PE) & Skelton Bow  
Handle (H1142.128.PE) from the Pewter Collection





# Chapter

CLASSIC COLLECTION



Doors: Chapter  
Textured Woodgrain Effect: Stone  
Handle: Berwick Knob (KDH3022) from the Pewter Collection



Doors: Chapter  
Textured Woodgrain Effect: Porcelain  
Handle: Kensington D-Handle  
(H768.128.CH) from the Chrome Collection



# Chapter

## CLASSIC COLLECTION

A decadent twist on a classic Shaker, the simple profile, textured woodgrain effect, ornate beading and neutral colour palette all help to create an elegant bedroom interior.

*Available in Porcelain as standard, and our full Painted Palette.*



Chapter shown in Partridge Grey with mirror



Archer handle (S87/55X10) from the Timber Collection



Chapter shown in Stone

Available finishes

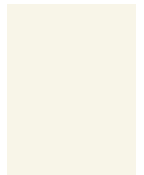

PORCELAIN



Painted palette





Doors: Chapter  
Textured Woodgrain Effect: Hartforth Blue  
Handles: Strand T-Bar (H1143.60.SS) & Strand Bar (H1144.242.SS) from the Stainless Steel Collection



# Hunton

CLASSIC COLLECTION



Doors: Hunton  
Smooth Painted Finish: Truffle & Georgian Red  
Handle: Didsbury Knob (K1120.33490BR) from the Antique Collection



# Hunton

## CLASSIC COLLECTION

With a narrow surround and a smooth painted finish, this classic, sophisticated Shaker is equally at home in any modern or traditional setting.

*Available in three beautiful shades as standard and our full Painted Palette.  
Also available with an Outline integrated handle.*



Hunton Cashmere wardrobes shown with internal bundle 9 in Walnut effect shown externally



Yeadon Knob (K1000.35.BS) from the Black Collection



Hunton Dust Grey wardrobe with double hanging

Available finishes

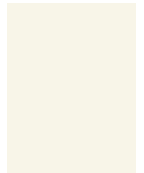

PORCELAIN



DOVE GREY

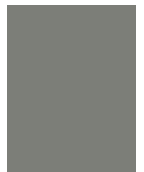

DUST GREY



Painted palette



OUTLINE







Doors: Hunton  
Smooth Painted Finish: Dry Rose & Porcelain  
Handles: Outline Edge with Brushed Brass backplate



# Mornington Beaded

CLASSIC COLLECTION



Doors: Mornington Beaded Edge  
Solid Timber: Copse Green  
Handle: Outline Edge with Brushed Brass backplate



Doors: Mornington Beaded  
Solid Timber: Cashmere  
Handle: Hexham T-Bar (H1167.75.CH) & Hexham D-  
Handle (H1166.160.CH) from the Chrome Collection  
Worktop: Strata Quartz Statuario 30mm

# Mornington Beaded

CLASSIC COLLECTION

Featuring an exquisite ash-grain finish, Mornington Beaded brings an intricate beading detail to a classic, solid timber Shaker door for a sophisticated bedroom look.

*Available in three beautiful shades as standard and our full Painted Palette. Also available with an Outline integrated handle.*



Island storage with integrated drawers & seating



Integrated dressing table with storage drawers & vanity drawer



Internal 4 drawer storage bundle in Oak effect

Available Finishes:

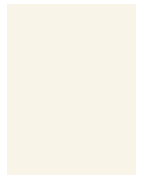

PORCELAIN

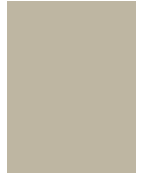

STONE



DOVE GREY



Painted palette



OUTLINE







Doors: Porter  
Painted Finish: Regents Green  
Handle: Outline Portal with Walnut backplate



# Modern

## COLLECTION

Featuring the Sculpt door with a distinct integrated handle, and the sleek, slab design of the Porter range, our modern collection effortlessly entwines simplicity and functionality to create sophisticated bedroom looks. Available in three neutral shades and one timeless grey, or in a range of unique colours as part of our extensive Painted Palette, our Modern Collection offers you the perfect canvas to develop your individual style.

Feature doors are also available in Bronze Tinted Glass or Silver Tinted Mirror to customise your modern bedroom look (see page 47).



# Porter

MODERN COLLECTION



Doors: Porter  
Painted Finish: Mussel  
Handle: Outline Extended Channel with Oak backplate



Doors: Porter  
Painted Finish: Charcoal  
Handle: Outline Extended Channel with Oak backplate

# Porter

## MODERN COLLECTION

With an effortless, linear appearance, the Porter door features a matt painted slab design that can adapt to any space, allowing you to create everything from the most minimal of looks, to the most glamorous of rooms.

*Available in four beautiful shades as standard, and our full Painted Palette.  
Also available with an Outline integrated handle.*



Porter Cashmere wardrobes with integrated shelving & drawers



Porter Cashmere dressing table with Darley Cup Handle (H1163.64.CH) from the Chrome collection



Porter Cashmere bedside chest with Darley Cup Handle (H1163.64.CH) from the Chrome collection

Available finishes  
Matt only

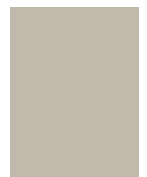

CASHMERE

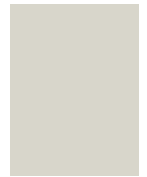

DOVE GREY

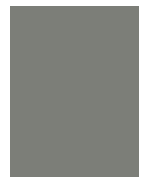

DUST GREY

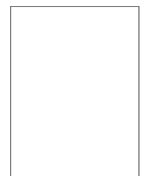

WHITE



Painted palette



OUTLINE





Doors: Porter  
Painted Finish: Regents Green  
Handle: Outline Portal with Walnut backplate



# Sculpt

MODERN COLLECTION





Doors: Sculpt & Silver Tinted Feature Mirror doors  
Painted Finish: Sage  
Handle: Jeaker Loop (H1149.80.BKLE) from the Material Collection



Doors: Sculpt  
Painted Finish: Silver Grey

# Sculpt

## MODERN COLLECTION

Inspired by Italian design, Sculpt is a matt painted slab, with an integrated handle carefully shaped into the edge of the door for a bold and distinctive look. The range creates a strong, structural statement that works perfectly across multiple interior styles.

*Available in four beautiful shades as standard, and our full Painted Palette.*



Sculpt Charcoal wardrobe with Bronze tinted Feature glass door



Sculpt doors shown in Cashmere, framed with COB tape lighting (see page 146)



Sculpt wardrobe shown in White

Available finishes  
Matt only

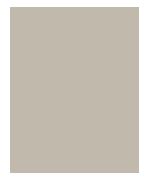

CASHMERE

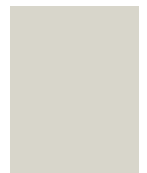

DOVE GREY

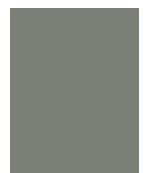

DUST GREY

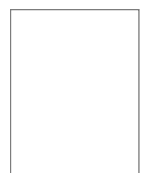

WHITE



Painted palette







Doors: Sculpt & Silver Tinted Feature Glazed door  
Painted Finish: Dust Grey & Bronze tinted feature glass door

# Feature Doors

Bring an extra decorative element to your classic or modern bedroom design with the addition of a refined feature door. Available in a subtle Bronze Tinted Glass or an elegant Silver Tinted Mirror, both feature door options are finished with a Satin Brown Frame and a matching trim handle for a sleek statement.



Sculpt Sage green wardrobe with Silver Tinted Mirror feature door



Walk in wardrobe with Silver Tinted Mirror feature doors



Silver Tinted Mirror feature doors



# Made-to-Measure

## COLLECTION

Whether your bedroom is small and compact, ultra-modern and minimal, or grand and full of character, our Made-to-Measure Collection can be tailored to the exact contours of your space, from wall-to-wall and floor-to-ceiling, allowing for complete versatility with design and function. Available in an array of unique colours and finishes, and with a selection of supporting accessories and angled doors, this collection is ideal for any shape and size bedroom.





Doors: Stanhope Bolam  
Finish: Matt Porcelain  
Handle: Yard Cup (H1138.160.MB) from the Black Collection

# Stanhope

MADE-TO-MEASURE COLLECTION





Doors: Stanhope; Elsdon  
Finish: Matt Blue Canvas  
Handle: Linton Bar (H1120.256.CH) from the Chrome Collection



Doors: Stanhope Bolam  
Finish: Matt Porcelain  
Handle: Yard Cup (H1138.160.MB) from the Black  
Collection Decorative Leg: Black Mounted Frame  
(MODF430BK)

# Stanhope

## MADE-TO-MEASURE COLLECTION

A fully made-to-measure vinyl door collection, Stanhope is available in five door styles, with a wide variety of matt, woodgrain effect, gloss, or feature concrete finishes, to help you seamlessly achieve both modern and classic looks. From the simplicity of Acomb or the versatility of Bolam, through to the elegance of Elsdon, the Stanhope collection showcases a selection of unique door designs to suit any bedroom style, truly highlighting the flexible nature of made-to-measure solutions.

Styles and finishes can be found on page 56.



Elsdon Blue Canvas wardrobes



Made-to-Measure dressing table solution with black mounted frames (MODF430BK)



Bolam angled wardrobe doors in Matt Porcelain with Yard Cup handle (H1138.160.MB) from the Black Collection





Bolam shown in Grey Woodgrain with Barton Cup handle (H1092.64.CH) & Barton Knob (K265.33.CH) from the Chrome Collection



Barton handle (H1092.64.CH) from the Chrome Collection



Made-to-measure chest of drawers with Linton Bar handles (H1120.160.CH) from the Chrome Collection



Made-to-measure bedside chest with Linton Bar handles (H1120.160.CH) from the Chrome Collection

# STANHOPE CLASSIC COLLECTION



ELSDON  
4 PANEL  
1 PIECE SHAKER

BOLAM  
1 PIECE SHAKER



AVAILABLE IN  
ANGLED DOORS

## MATT



PORCELAIN



DOVE GREY



CASHMERE



DUST GREY



BLUE  
CANVAS



INDIGO  
BLUE



THORPE  
GREEN



GRAPHITE



MATT BLACK

## WOODGRAIN



SUPER WHITE



CREAM



GREY



MUSSEL



CASHMERE



# STANHOPE MODERN COLLECTION

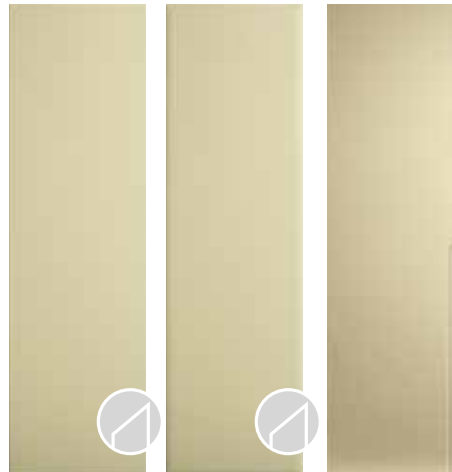

WHITFIELD  
SQUARE SLAB

HENSHAW  
SAPPIONETTA  
SLAB

ACOMB  
INTEGRATED  
HANDLE  
*Not available  
in Gloss*



AVAILABLE IN  
ANGLED DOORS

## GLOSS



WHITE



CREAM



DOVE GREY



CASHMERE



DUST GREY

## MATT



PORCELAIN



DOVE GREY



CASHMERE



DUST GREY



BLUE  
CANVAS



INDIGO  
BLUE



THORPE  
GREEN



GRAPHITE



MATT BLACK

## FEATURE



CONCRETE  
(LIGHT GREY  
BACK)

## WOODGRAIN



SUPER  
WHITE



CREAM



GREY



MUSSEL



CASHMERE



# Unity

MADE-TO-MEASURE COLLECTION



Doors: Unity  
Finish: Supermatt Pure White  
Handle: Soho Trim (H1131.250.MW) from the White Collection



# Unity

## MADE-TO-MEASURE COLLECTION

Minimalist and un-complicated in design, the pure, linear aesthetic of Unity enables it to adapt to any space with true flexibility. Whether your style is effortlessly simplistic, or sophisticated and full of character, select from over 20 unique shades across lustrous gloss, smooth matt, gloss metallic and woodgrain finishes, to bring your bedroom vision to life. Fully customise your look with added edging options, including the distinctive multiplex edging.

Colour finishes can be found on page 64.



Matt White doors with Yard D-Handle from the White Collection (H1137.160.MW)



White Halifax Oak floating dressing table



White Halifax Oak floating Bedside with Soho Trim handle from

Available Edge Options



Matching AirTech Edge



Two-Tone 3D glass effect  
(Gloss & metallic doors only)



Multiplex Edging



Unity shown in Matt White & Matt Light Grey



Handle from the Knurled Collection (K1111.20B384AGB)



Made-to-measure bedside with open section & Chrome finish legs (DL120CH)



Made-to-measure combination wardrobe



Doors: Unity  
Finish: Gloss & Matt Cashmere with Gold Gloss Metallic features  
Handles: Knurled Knob with backplate (K1111.20B384AGB)  
& Bar with backplate (H1126448B385AGB) from the Knurled Collection

# UNITY COLLECTION

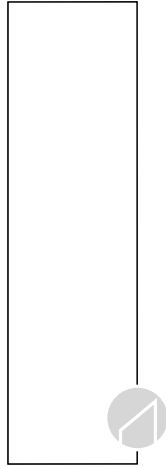

SQUARE  
SLAB



AVAILABLE IN  
ANGLED DOORS

## EDGE OPTIONS



MATCHING AIRTECH EDGE



TWO-TONE 3D GLASS EFFECT  
(GLOSS & METALLIC  
DOORS ONLY)



MULTIPLEX EDGING



WOODGRAIN EFFECT (Matching edge only)

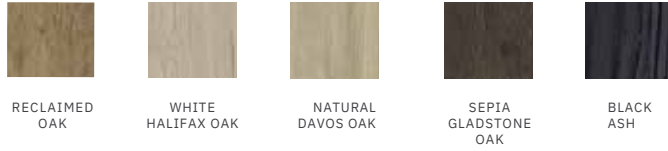

GLOSS FINISHES



GLOSS METALLIC FINISHES



FEATURE CONCRETE

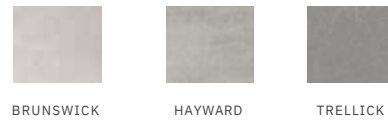

SUPERMATT FINISHES (Matching edge only)





# Sliding

MADE-TO-MEASURE COLLECTION



Frame: Satin Silver - Shape  
Doors: Full panel & equal 3 panel  
design Finish: Silver mirror &  
Anthracite glass



Frame: Satin Silver -  
Cube Doors: Equal two  
Finish: White Glass

# Sliding

## MADE-TO-MEASURE COLLECTION

Whether your home has impressively high ceilings, or a quaint cottage footprint, a sliding wardrobe is the perfect solution to maximise and utilise space for all your storage needs. With an extensive range of glass, satin glass, mirror and panel options, your sliding wardrobe can be tailored to perfectly suit your bedroom style, and with our flexible YouK internal shelving solution (see page 84), your storage can be personalised to truly fit your requirements.



FULL PANEL



EQUAL TWO



LOW 400



CENTRAL 400



EQUAL THREE

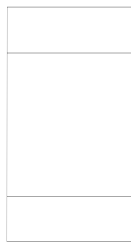

WIDE 400



WIDE 300



Full panel, mixed Gloss Cashmere board & Matt White board



Wide 400, Matt Cashmere board & Satin Stone glass



Liner

Top track

Doors

Rail Profile

Liner

Runners/wheels

Bottom track

Liner

# Frame profile and colour

Choose from three different frame shapes and six different colour options to tailor your wardrobe to your personal taste.



CURVE\*

\*curve can only be used on glass doors only



CUBE



SHAPE

## FRAME PROFILE COLOURS



SATIN SILVER



WHITE GLOSS



BLACK GLOSS



CHAMPAGNE



CASHMERE



MATT BLACK

# Door colours for your chosen door style

Choose from over 30 door colour options ranging from glass, satin glass, mirror, matt, gloss and textured woodgrain boards. Board colours and woodgrain boards can also be used to create filler pieces and internal options.

			MIRROR BOARD COLOURS			WOODGRAIN BOARDS		
SILVER MIRROR			GLOSS - WHITE		MATT - WHITE		CLASSIC PORCELAIN	
BRONZE MIRROR			GLOSS - DOVE GREY		MATT - DOVE GREY		CLASSIC GREY	
GREY MIRROR			GLOSS - CASHMERE		MATT - CASHMERE		CLASSIC STONE	
					MATT - ANTHRACITE		OAK	
<b>GLASS COLOURS</b>								
W H I T E		CASHMERE		BLUE SHADOW			WALN UT	
RICH ALUMINIUM		DAKAR		ANTH RACITE			BEIGE LINEN	
CLASSIC GREY		STONE GREY		STARLIGHT BLACK			GREY LINEN	
		METAL TAUPE						
<b>SATIN GLASS COLOURS</b>								
SATIN WHITE		SATIN CASHMERE		SATIN BRONZE				
SATIN SILVER		SATIN DAKAR		SATIN ANTHRACITE				
SATIN GREY		SATIN STONE GREY		SATIN BLACK				

TEXTURED LINEN END PANELS & LINERS ARE ONLY RECOMMENDED FOR INTERNALS



Walk-in  
COLLECTION





Collection: Walk-in  
Finish: Linen Walk-In wardrobe with Porter White accessories & Walnut Effect internals



# Walk-in

COLLECTION

Adapting to any space, create the ultimate walk-in closet with our open wardrobes in textured Linen. By combining our wardrobes, with our collection of Walnut, Oak and Linen internal accessories you can customise to any storage requirement.

Frame and finish with modern or classic accessories for the ultimate luxurious style.



Pigeon Hole storage & stackable drawers in Walnut effect



Linen effect drawer organiser grill



Shoe display in Walnut effect, made from shallow stackable drawers

# Internals

COLLECTION

Practical, flexible and beautiful in design, our internal storage solutions have been carefully considered to work around your needs. Choose from stackable drawers, accent shelves, drawer organisers, shoe storage and pigeon units. Available in Walnut, Oak and Linen finishes.

For ultimate flexibility, our clever YouK modular system is also available to transform your sliding wardrobe internals and open shelving designs.





# INTERNALS



## ACCESSORY FINISH



TEXTURED LINEN



TEXTURED WALNUT



TEXTURED OAK

## SHELVES

Add more storage with 22m thick shelves available in Linen, Oak and Walnut.

Sold in pairs our additional shelves are designed to fit

inside  
all of our wardrobe widths.

## HANGING RAIL

Available in a premium Satin Brown finish, our hanging rails perfectly complements the Textured Linen cabinet. Designed to fit the internal size of all of our cabinet widths.



## CORNER SHELVING

Further maximise the space available. Available in Linen, our corner shelving unit is the perfect storage solution when trying to maximise cupboard space.

## CORNER WARDROBE SHELF PACK

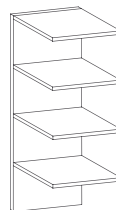



## SINGLE STACKABLE DRAWER

With Linen, Walnut and Oak drawer fronts, coupled with a Linen drawer box, our stackable drawers are available in shallow and deep drawer heights and fit inside a 500, 800, 900 and 1000mm wardrobe widths. Place them individually or in multiples within your wardrobe for as much or as little additional storage as you need.

Fully extendable soft close runners as standard add to the premium quality of the additional storage.



## BUNDLES

To meet your storage requirements, we have combined individual stackable drawers to create bundles. Choose from 3 and 4 drawer bundles in widths to fit 500, 800, 900 and 1000mm wardrobes.

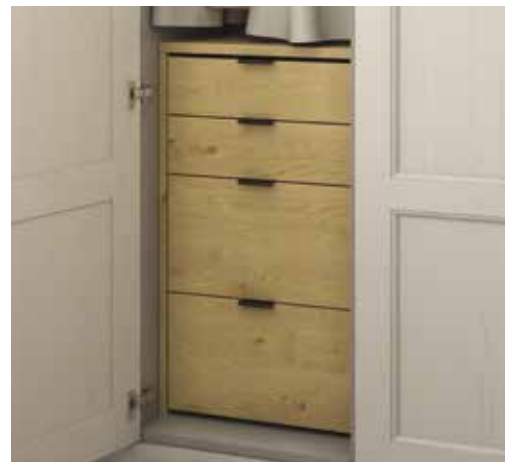

# INTERNALS



ACCESSORY FINISH



TEXTURED LINEN



TEXTURED WALNUT



TEXTURED OAK

## DRAWER ORGANISER GRILL

Designed to work perfectly within the 1000mm shallow stackable drawer, this Linen drawer organiser can help to organise your smallest possessions. It can cut to size to work within smaller drawer widths and chests of drawers.



## FELT DRAWER LINER

The felt drawer liner comes pre-cut. Designed to fit the 1000mm stackable drawer, this soft grey felt liner is the perfect addition to any drawer base. This can be cut to fit smaller drawer widths if you would like to use it within bedside drawers, or smaller stackable drawers.

Working best underneath the Linen drawer organiser grill, the felt drawer liner acts an attractive non-slip solution for items such as sunglasses, watches and jewellery.



## PIGEON HOLE

Designed only to suit the 1000mm width wardrobe, the Pigeon hole unit is designed to create a practical yet premium looking storage display for your wardrobe. Use the clever compartments to store perfume bottles, handbags, shoes or folded clothing items for an easy to reach and useful display solution. Available in Linen, Walnut and Oak.







### SHOE RACK CONVERSION KIT

This simple element comes only in a Linen finish to match perfectly with the textured Linen cabinet. Supplied in one width – 1000mm with two stabilising end supports. It can be cut down to suit any of our wardrobe widths. Simply place the conversion kit on the bottom of a wardrobe or on shelves for a perfect shoe display.



### SHOE DISPLAY

Created with shallow stackable drawers

Why not combine our shoe rack conversion with our shallow height drawers to create a flawless and easy to access shoe storage display.



# BUNDLES



## ACCESSORY FINISH



TEXTURED LINEN



TEXTURED WALNUT



TEXTURED OAK

## BUNDLES

If you can't choose what is best for your storage needs, why not take a look at our predetermined wardrobe bundles available in Linen, Oak and Walnut. Designed to make your life easier we have 10 predetermined bundles for 500, 800 and 900mm wardrobes and 16 predetermined bundles for 1000mm wardrobes. We have done the hard work so you don't have to!







# YouK Modular Furniture System

A fully flexible and versatile storage solution, the YouK modular furniture system allows you to create truly tailored storage to suit your every need, from simple wall-mounted open shelving, through to walk-in-wardrobes, sliding wardrobes and home-office spaces.

The system features a matt-black, steel ladder design and shelving can be brought to life with the choice of five woodgrain effect or three concrete finishes.

## CHOOSE YOUR PRE-ASSEMBLED YouK ELEMENTS

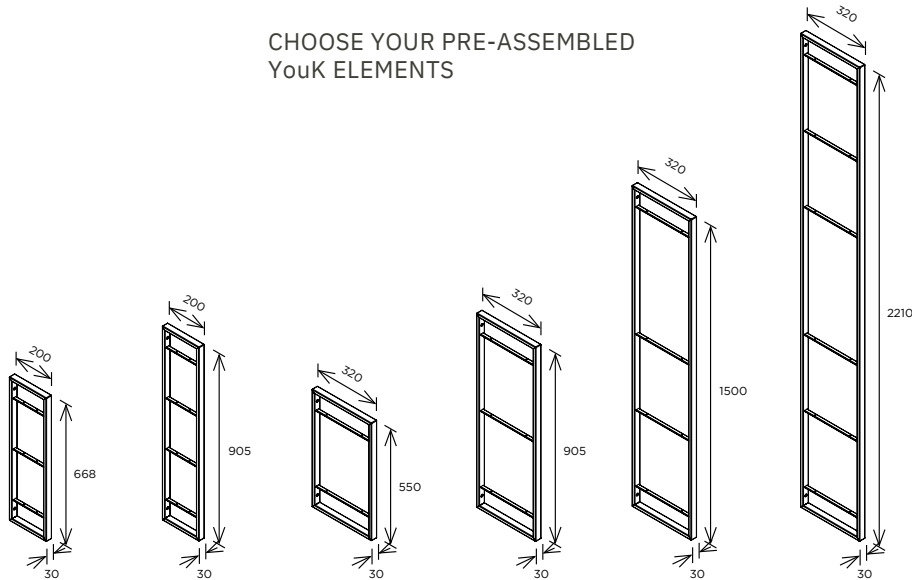

## CHOOSE A FINISH THAT BEST SUITS YOUR STYLE

### WOODGRAIN EFFECT



### CONCRETE FINISHES

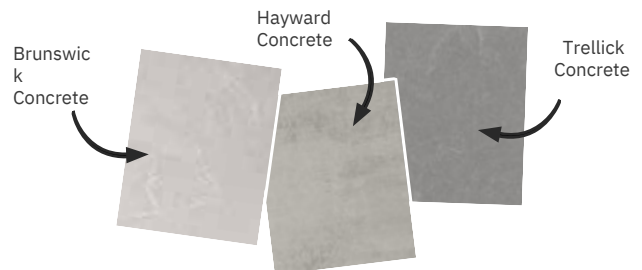

## ADDITIONAL YouK ELEMENTS



### TOP SHELF BRACKET

Pair of brackets to enable shelving element to be screwed on the top section of a YouK frame profile.



### HANGING RAIL

(Standard)



### HANGING RAIL

(Extender)



### CLOTHES HOOK RAIL



### SHOE RACK



### CABINET FIXING BRACKETS

Brackets enable cabinets to be quickly & easily attached directly to any 320mm deep YouK ladder systems.

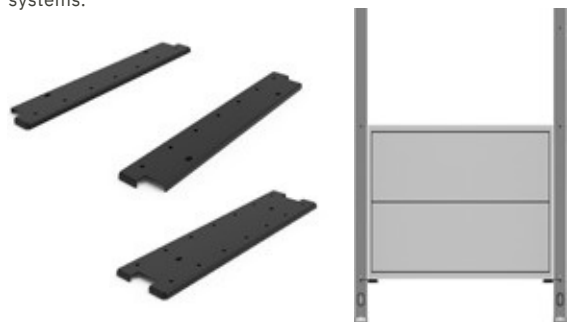

### DESK BRACKET

The Desk Brackets allow the YouK ladder system to quickly and securely be fixed to a desktop element, which can be attached horizontally or tilted.







Doors: Hunton  
Smooth Painted Finish: Georgian Red  
Handle: Outline Brushed Brass  
Worktop: Strata Quartz Pietra Auburn 30mm



# Home Office

## COLLECTION

From the elegant detail of the Mornington Beaded door, to the linear simplicity of the Porter Slab, our Home Office ranges combine a variety of strong looks with impressive functionality. Whatever your space, individual style or specific home-working requirements, our flexible collection can transform your dedicated workspace into the organised haven you've been dreaming of.

Available in an array of timeless shades as standard, or in a range of unique colours as part of our extensive Painted Palette, the Home Office Collection allows you to create a workspace you'll truly love spending time in.



# Belsay

CLASSIC COLLECTION



Doors: Belsay  
Textured Woodgrain Effect: Dove Grey  
Handles: Linton T-Bar (H1120.60.CH) & Linton Bar Handle (H1120.160.CH) from the Chrome Collection



Doors: Belsay  
Textured Woodgrain Effect: Cashmere  
Handles: Linton T-Bar (H1120.60.CH) & Linton  
Bar (H1120.160.CH) from the Chrome Collection

# Belsay

## CLASSIC COLLECTION

A contemporary twist on the classic Shaker style, Belsay features a narrow frame, a sophisticated chamfer detail and a textured woodgrain effect, perfect for creating a timeless home office look.

*Available in three beautiful neutral shades as standard, and our full Painted Palette.*

Available Finishes

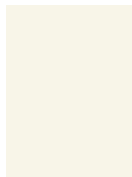

PORCELAIN



CASHMERE

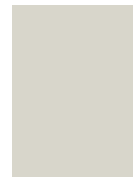

DOVE GREY



Painted palette



Crathorne  
CLASSIC COLLECTION



Doors: Crathorne  
Solid Timber: Hartforth Blue  
Handle: Hampstead Knob (K1126.30.WABHB) from the Material  
Collection Worktop: Strata Granite Sinuous White 30mm





# Crathorne

CLASSIC COLLECTION

With an elegant narrow Shaker design and a distinctive ash grain texture, the solid timber Crathorne door lends itself perfectly to both classic and contemporary home office designs.

*Available in two neutral shades and our bold Hartforth Blue as standard, as well as our full Painted Palette. Also available with an Outline integrated handle.*

#### Available Finishes

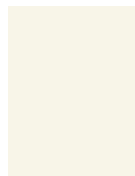

PORCELAIN

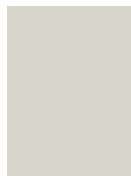

DOVE GREY



HARTFORTH  
BLUE



Painted palette





# Hunton

CLASSIC COLLECTION



Doors: Hunton  
Smooth Painted Finish: Charcoal  
Handle: Gales Bar (H1169.160.SB) from the Metallics  
Collection Worktop: Strata Quartz White Venato 30mm



# Hunton

## CLASSIC COLLECTION

A modern interpretation of the traditional Shaker style, the versatile Hunton door features a narrow surround and a smooth painted finish.

*Available in two neutral shades and two statement tones as standard, as well as our full Painted Palette. Also available with an Outline integrated handle.*

### Available Finishes

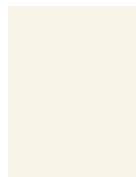

PORCELAIN

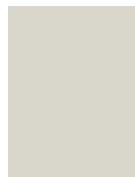

DOVE GREY



DUST GREY



HARTFORTH  
BLUE



Painted palette



OUTLINE



# Mornington Beaded

CLASSIC COLLECTION



Doors: Mornington Beaded  
Solid Timber: Dust Grey  
Handle: Harton Knob (K1118.31.BN) & Harton Cup (H1146.105.BN) from the Nickel  
Collection Worktop: Strata Quartz Marbled White 30mm



Doors: Mornington Beaded  
Solid Timber: Dust Grey  
Handle: Harton Knob (K1118.31.BN) & Harton  
Cup (H1146.105.BN) from the Nickel Collection  
Worktop: Strata Quartz Marbled White 30mm



# Mornington Beaded

CLASSIC COLLECTION

The solid timber Mornington Beaded door showcases the elegance of a classic Shaker style with the addition of an intricate beading detail and an exquisite ash grain finish, perfect for creating a truly sophisticated home office aesthetic.

*Available in three neutral shades and our bold Hartforth Blue as standard, as well as our full Painted Palette. Also available with an Outline integrated handle.*

Available Finishes

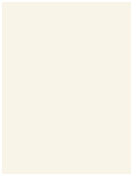

PORCELAIN



STONE

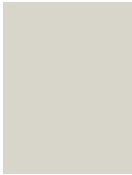

DOVE GREY



HARTFORTH  
BLUE



Painted palette



OUTLINE



# Mornington Shaker

CLASSIC COLLECTION



Doors: Mornington Shaker  
Solid Timber: Regiment  
Handle: Belgrave Pull Handle (8/951.B.MB) from the Black  
Collection Worktop: Strata Quartz Imperial 20mm



Doors: Mornington Shaker  
Solid Timber: Regiment  
Handle: Belgrave Pull Handle (8/951.B.MB)  
from the Black Collection  
Worktop: Strata Quartz Imperial 20mm

# Mornington Shaker

CLASSIC COLLECTION

With clean lines and an elegant frame, the solid timber Mornington Shaker range embodies the classic Shaker style, finished with a beautiful ash grain texture.

*Available in three neutral shades and our bold Hartforth Blue as standard, as well as our full Painted Palette. Also available with an Outline integrated handle.*

## Available Finishes

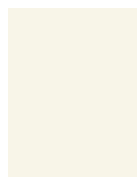

PORCELAIN



STONE



DOVE GREY



HARTFORTH  
BLUE



Painted palette



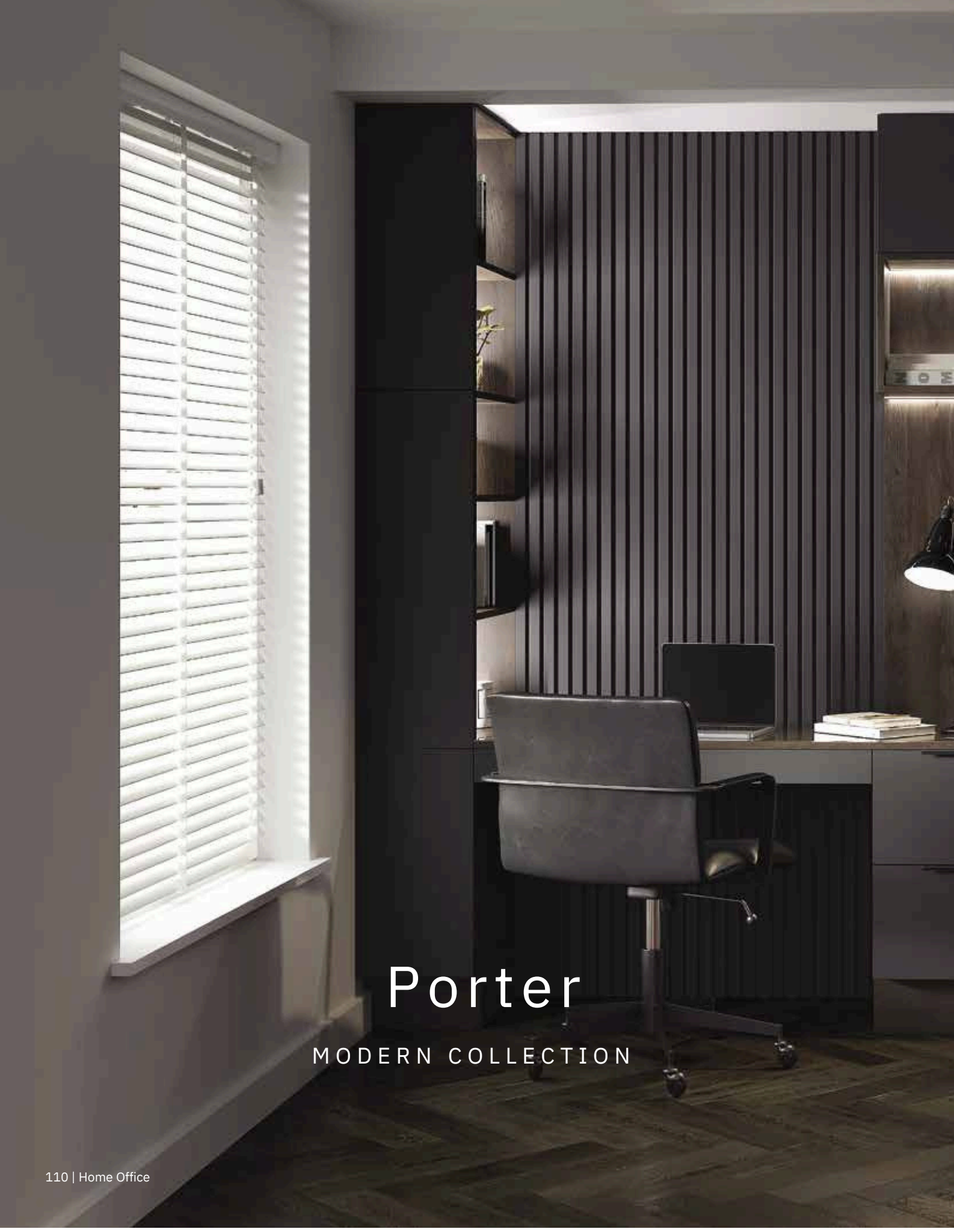

# Porter

MODERN COLLECTION



Doors: Porter  
Finish: Matt Graphite & Unity Sepia Gladstone Oak  
Handle: Soho Trim (H1131.90.MB) from the Black Collection  
Worktop: Unity Sepia Gladstone Oak with 3mm bespoke glass on top





# Porter

## MODERN COLLECTION

Offering an effortless, linear appearance, Porter is a slab door with a matt painted finish, perfect for creating a sleek, contemporary workstation. With its simplistic aesthetic, this range offers an ideal canvas for bringing personality through colour, accessories, and textures.

*Available in three neutral shades and two statement tones as standard, as well as our full Painted Palette. Also available with an Outline integrated handle.*

Available Finishes, Matt only



Painted palette





# Finishing Touches

Although small, the finishing touches play a big part in determining the overall look of your bedroom and home office. Once you've chosen your door range and visualised your design, it's time to choose the finishing touches to bring your space to life.

With an extensive colour palette, a wide choice of handle designs and finishes, our unique Outline integrated handle collection, and a selection of effective lighting solutions, we have all the finer details you could need to complete your classic and contemporary looks.

Painted Palette	116
Outline	120
Handle Collection	124
Lighting	144
Collection	



# Painted Palette



Wherever you see our Painted Palette symbol, this range can be painted in any of our 35 beautiful matt paint-to-order colours, from warm neutrals and timeless greys, to forest greens and ink blues. Solid timber and Woodgrain effect finishes can also be painted whilst retaining the textured detail.



Hunton shown in Truffle & Georgian Red



Porter shown in Regents Green



Hunton shown in Charcoal

# 35 Colours

TO CHOOSE FROM



From muted neutrals and warming tones, to vibrant, dramatic shades, our Painted Palette includes 35 carefully considered matt colours, to help you create the perfect bedroom or home office to reflect your individual tastes.

Opt for a unified colour scheme or embrace a combination of shades for striking statement.

## NEUTRALS



WHITE

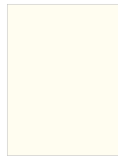

CHALK

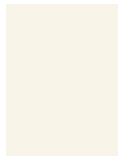

PORCELAIN



ALABASTER MODERN



MUSSEL



STONE

## GREYS

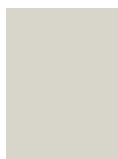

DOVE GREY



SILVER GREY



PUTTY



DUST GREY



SLATE



GRAPHITE



CARBON

NOTE: Whilst every effort has been made to accurately represent painted colours, actual product colours may vary slightly from colours shown in this brochure.

If opting for a dark bedroom, it is worth noting that darker shades can show up fingerprint marks more easily than lighter finishes, however these are easily removed with a soft Microfibre anti-scratch cloth.

## WARM NEUTRALS



CASHMERE



DRY ROSE



PIMENTO



GEORGIAN RED



TRUFFLE



LAVA

## OLIVE GREENS



SAGE



O LIVE



BAY GREEN



REGIMENT



REGENTS GREEN

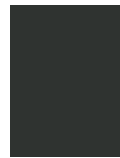

COPSE GREEN

## FOREST GREENS

## GREEN BLUES

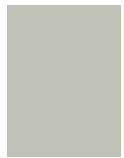

PARTRIDGE GREY



CHINA BLUE



CHALK BLUE



STORM BLUE



HARTFORTH BLUE



CHAR COAL

## INK BLUES



IVES BLUE



CAD ET



CORNFLOWER



INKWELL



Look out for this symbol where door families are available in our full Painted Palette

# OUTLINE

A unique, bespoke integrated handle collection full of character and charm, Outline allows you to create a bedroom or home office environment as individual as you are.



Mornington Beaded Edge

## CHOOSE FROM FOUR BEAUTIFULLY FORMED HANDLE OPTIONS

### PORTAL

The timeless, circular shape of Portal offers an elegant and soft handle choice, that works particularly well when paired with a modern door range. Portals distinctive round backplate, captures an eclectic and retro feel.

Available on Porter.



Porter Portal



## EDGE

Subtly sculpted into the perimeter of the door, Edge offers a refined and considered handle that is equally suited to modern or traditional settings. Its beautifully curved corners soften the overall design, whilst adding depth and interest.

Available on Porter, Hunton, Crathorne, Mornington Beaded & Mornington Shaker.



## CHANNEL

The linear appearance and striking rectangular backplate of Channel offers a contemporary and reserved handle with a subtle emphasis towards flow and movement, synonymous with a seamlessly sleek design.

Available on Porter.



## EXTENDED CHANNEL

A natural evolution of Channel, Extended Channel's bold, geometric shape creates a beautifully sleek, ultra-modern appearance for a functional yet adventurous handle, perfectly suited to the modern-day homeowner.

Available on Porter.



PAIR ANY OF THESE VERY DIFFERENT  
HANDLE CHOICES WITH AN ARRAY  
OF DISTINCTIVE BACKPLATES

TIMBER



OAK



WALNUT

PAINTED



MATCHING



CARBON

METALLIC



ANTIQUÉ BRONZE  
EFFECT



AGED BRASS







BRUSHED BRASS



BRIGHT COPPER

CHOOSE FROM 8 COMBINATIONS

				
PORTER				
*CRATHORNE	-		-	-
HUNTON	-		-	-
*MORNINGTON SHAKER	-		-	-
MORNINGTON BEADED	-		-	-

\*Home Office only





# Handle

COLLECTION

With a choice of over 150 beautiful handles in both classic and contemporary designs, and in an array of striking finishes, you're guaranteed to find the perfect style for your bedroom or home office space in our collection.

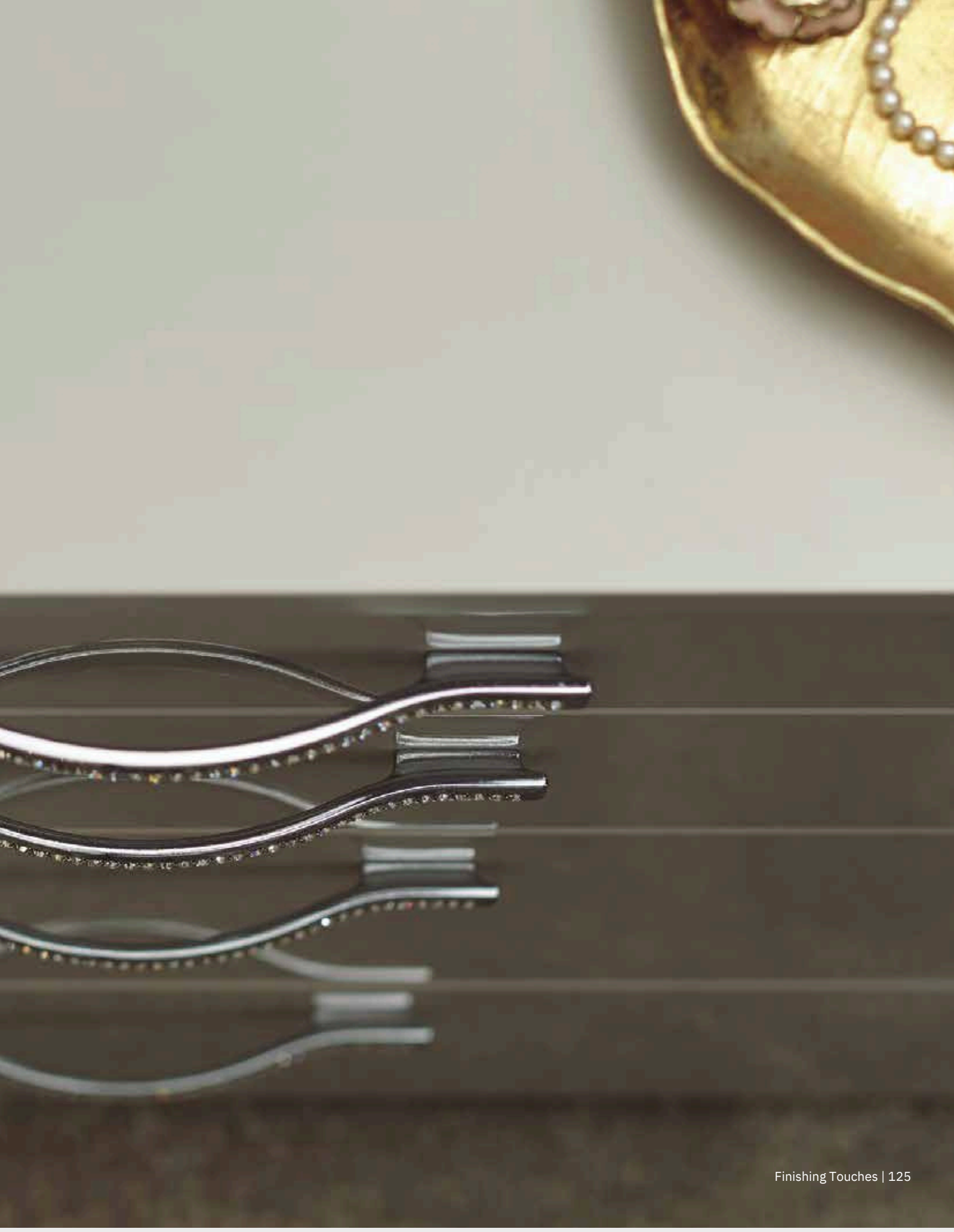



Cheadle Block Handle (KDH3000)

## STAINLESS STEEL



Portland  
Knob  
Handle 1  
TK2SS



Portland  
Cup Handle  
1 1003/79SS



Guilford  
Cup Handle  
3 H1029.128.SS



Marylebone  
Trim handle  
1 H1087.160.SS



Cheadle  
Block Handle  
3 KDH3000  
3 KDH3001



Thorpe  
Bar Handle  
2 H109.188.SS 2  
H110.237.SS



Didsbury  
Knob Handle  
2 K1120.33490SS



Didsbury  
Knurled T-Bar  
Handle 2  
H1158.72.SS



Didsbury  
Knurled T-Bar Handle  
3 H1158.72B496SS



Didsbury  
D-Handle  
3 H1140.160.SS 3  
H1140.192.SS



Didsbury  
D-Handle  
3 H1140.160497SS



Arlington  
T-Bar Handle  
1 H503.60.SS



Arlington  
Bar Handle  
1 H503.128.SS



Strand  
Bar Handle  
3 H1144.242.SS



Strand  
T-Bar Handle  
2 H1143.60.SS



Yard  
D-Handle  
1 H745.128.SS  
1 H746.192.SS



Leven  
Bow Handle  
1 H251.160.SS



Seamer  
Bow Handle  
2 H1012.160.SS

PRICE BANDS  
1 2 3 4 5



Linton Bar Handle (H1120.256.CH)



## CHROME



Barnard  
Knob Handle  
5 K1129.32.CH



Barton  
Knob Handle  
1 K265.33.CH



Yeadon  
Knob Handle  
2 K999.38.CH



Yeadon  
Knob Handle  
2 K1000.35.CH



Barton  
Cup Handle  
1 H1092.64.CH



Collingwood  
Cup Handle  
5 H1127.76.CH



Darley  
Cup Handle  
1 H1163.64.CH



Sutton  
Flat Handle  
1 KDH3030



Hexham  
T-Bar Handle  
2 H1167.75.CH



Hexham  
D-Handle  
3 H1166.160.CH



Fimber  
D-Handle  
3 KDH3029



Linton  
T-Bar Handle  
2 H1120.60.CH



Linton  
Bar Handle  
3 H1120.160.CH  
3 H1120.256.CH



Darlington  
D-Handle  
2 KDH3027  
3 KDH3028



Hoxton  
D-Handle  
2 H1085.160.CH



Dalton  
D-Handle  
2 H1168.160.CH



Yarm  
Pull Handle  
2 H1162.192.CH



Yarm  
Knob Handle  
1 K1131.30.CH



Kensington  
D-Handle  
3 H768.128.CH

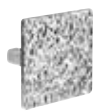

Kensington  
Knob Handle  
5 K1043.32.CH



Kensington  
D-Handle  
5 H1044.128.CH

PRICE BANDS  
1 2 3 4 5



Berwick Bar Handle (H1063.96.PE)

## SATIN NICKEL & NICKEL



Chelsea  
Knob Handle  
1 K419.32.DN



Chelsea  
D-Handle  
2 H420.128.DN



Belgrave  
Knob Handle  
2 K1107.35.SN



Belgrave  
Cup Handle  
1 8/952.B.SN



Belgrave  
Bow Handle  
1 8/951.B.SN



Healey  
Bow Handle  
1 8/965.B.SN



Harton  
Knob Handle  
2 K1118.31.BN



Leeming  
T-Bar Handle  
2 H1003.62.BN



Leeming  
Bar Handle  
3 H1002.160.BN



Strand  
T-Bar Handle  
2 H1143.60.BN



Strand  
Bar Handle  
3 H1144.242.BN



Harton  
Cup Handle  
2 H1146.105.BN

## PEWTER



Berwick  
Knob Handle  
3 K1062.30.PE



Berwick  
Knob Handle  
3 KDH3022



Chatsworth  
Knob Handle  
4 K1109.35.PE



Hampshire  
Knob Handle  
3 K886.30.PE



Skelton  
T-Bar Handle  
4 K1115.80.PE



Cromwell  
Cup Handle  
4 H1111.64.PE



Skelton  
Bow Handle  
5 H1142.128.PE



Berwick  
Bar Handle  
5 H1063.96.PE



Yeal  
Pull Handle  
5 H1159.160.PE



Stivichall  
Knob Handle  
1 K265.33.PE



Mayfair  
Bow Handle  
2 H267.96.PE

PRICE BANDS  
1 2 3 4 5



Knurled Bar Handle (H1126448B385AGB)

# KNURLED

## Stainless Steel



Knob Handle  
1 K1117.32.SS



Knob Handle  
3 K1111.20B384SS



Bar Handle  
4 H1126.257.SS



Bar Handle  
5 H1126.448.SS



Bar Handle  
5 H1126.448B385SS



T-Bar Handle  
2 H1125.35.SS



T-Bar Handle  
3 H1125.35B385SS

## Aged Brass



Knob Handle  
2 K1117.32.AGB



Knob Handle  
3 K1111.20B384AGB



Bar Handle  
4 H1126.257.AGB



Bar Handle  
5 H1126.448.AGB



Bar Handle  
5 H1126448B385AGB

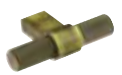

T-Bar Handle  
3 H1125.35.AGB



T-Bar Handle  
4 H1125.35B385AGB

## Matt Black



Knob Handle  
1 K1117.32.MB



Knob Handle  
3 K1111.20B384MB



Bar Handle  
4 H1126.257.MB



Bar Handle  
5 H1126.448.MB



Bar Handle  
5 H1126.448B385MB



T-Bar Handle  
2 H1125.35.MB



T-Bar Handle  
3 H1125.35B385MB

PRICE BANDS  
1 2 3 4 5



Bloomfield T-Bar Handle (H995.68.BS)

BLACK



Barton  
Knob Handle  
1 K1110.33.BS



Yeadon  
Knob Handle  
3 K1000.35.BS



Bloomfield  
T-Bar Handle  
1 H995.68.BS



Barton  
Cup Handle  
1 H1092.64.BS



Bloomfield  
Bar Handle  
3 H994.160.BS



Marylebone  
Trim Handle  
1 H1087.160.BS 2  
H1087.256.BS



Askern  
D-Handle  
2 H1082.160.BS



Belgrave  
Knob Handle  
1 K1107.35.MB



Soho  
Trim handle  
2 H1131.90.MB



Hove  
D-Handle  
2 H1130.160.MB



Yard  
Knob Handle  
1 K1123.33.MB



Belgrave  
Pull Handle  
1 8/951.B.MB



Dalton  
D-Handle  
1 H1168.128.MB  
2 H1168.160.MB



Hexham  
D-Handle  
2 H1166.160.MB



Hexham  
T-Bar Handle  
2 H1167.75.MB



Didsbury  
Knurled T-Bar Handle  
2 H1158.72B496MB



Didsbury  
D-Handle  
3 H1140.192.MB



Tarn  
Knob Handle  
1 K1132.18.MB



Tarn  
Bar Handle  
2 H1164.160.MB



Hoxton  
Cup Handle  
2 H1104.96.SMB



Claremont  
Cup Handle  
2 H1105.64.MB



Yard  
D-Handle  
1 H1137.160.MB  
2 H1137.224.MB



Yard  
Cup Handle  
1 H1138.64.MB 2  
H1138.160.MB



Claremont  
Knob Handle  
1 K1106.30.MB



Hoxton  
D-Handle  
2 H1109.160.MB



Didsbury  
D-Handle  
3 H1140.160497MB



Didsbury  
Knurled T-Bar  
Handle 2  
H1158.72.MB

PRICE BANDS  
1 2 3 4 5



Gales Bar Handle (H1169.160.SB)



## METALLICS

### Bright Copper



Yard  
D-Handle  
1 H1137.160.CO  
2 H1137.224.CO



Yard  
Knob Handle  
1 K1123.33.CO

### Aged Copper



Hoxton  
D-Handle  
2 H1085.160.AC



Eldon  
Bar Handle  
2 H1084.128.AC  
2 H1084.160.AC

### Burnt Copper



Dale  
Knob Handle  
2 K557.35.BC



Ripon  
Bow Handle  
2 H1086.160.BC

### Brushed Brass



Hessay  
D-Handle  
2 H1133.160.BHB  
4 H1133.320.BHB



Lloyd  
Knob Handle  
1 K1124.25.BHB



Lloyd  
D-Handle  
2 H1156.160.BHB

### Satin Brass



Gales  
T-Bar Handle  
4 H1170.75.SB



Gales  
Bar Handle  
5 H1169.160.SB



Barnard  
Knob Handle  
5 K1129.32.SB



Tarn  
Knob Handle  
1 K1132.18.SB



Tarn  
Bar Handle  
3 H1164.160.SB



Dunston  
Knob Handle  
2 K1125.25.SB



Dunston  
D-Handle  
2 H1153.192.SB

PRICE BANDS  
1 2 3 4 5



Hexham T-Bar Handle (H1167.75.AG)

## METALLICS

### Aged Brass



Harton  
Knob Handle  
2 K1118.31.AGB



Dartmouth  
T-Bar Handle  
3 H1123.60.AGB



Dartmouth  
Bar Handle  
4 H1128.160.AGB



Yard  
D-Handle  
1 H1137.160.AGB  
2 H1137.224.AGB



Yard  
Cup Handle  
1 H1138.64.AGB  
2 H1138.160.AGB



Belgrave  
Knob Handle  
1 K1107.35.AGB



Belgrave  
Cup Handle  
1 8/952.B.AGB



Belgrave  
Pull Handle  
1 8/951.B.AGB



Hexham  
D-Handle  
3 H1166.160.AGB



Hexham  
T-Bar Handle  
1 H1167.75.AG



Didsbury  
Knob Handle  
2 K1120.33490.AGB



Didsbury  
D-Handle  
3 H1140.192.AGB



Harton  
Cup Handle  
2 H1146.105.AGB



Strand  
T-Bar Handle  
2 H1143.60.AGB



Didsbury  
T-Bar Handle  
2 H1158.72.AGB



Didsbury  
D-Handle  
4 H1140.160497.AGB

## ANTIQUE

### Antique Bronze



Claremont  
Knob Handle  
1 K1106.30.BR



Claremont  
D-Handle  
2 H1103.160.BR



Didsbury  
Knob Handle  
2 K1120.33490BR



Didsbury  
D-Handle  
3 H1140.192.BR



Didsbury  
D-Handle  
4 H1140.160497BR



Didsbury  
T-Bar Handle  
2 H1158.72.BR

PRICE BANDS  
1 2 3 4 5



Jeaker Loop Handle (H1149.80.BKLE)

## WHITE



Hove  
D-Handle  
2 H1130.160.MW  
2 H1130.320.MW



Soho  
Trim Handle  
2 H1131.90.MW  
4 H1131.250.MW



Yard  
D-Handle  
1 H1137.160.MW  
2 H1137.224.MW

## MATERIAL

Leather



Jeaker  
Loop Handle  
2 H1149.80.BWNLE



Jeaker  
Loop Handle  
2 H1149.80.BKLE



Jeaker  
Bow handle  
3 H1150.160.BWNLE



Jeaker  
Bow handle  
3 H1150.160.BKLE

PRICE BANDS  
1 2 3 4 5



Hampstead Walnut & Brushed Brass Knob Handle (K1126.30.WABHB)

## MATERIAL

### Glass



Aztec  
Knob Handle  
2 KDH3042



Crystal  
Bow Handle  
4 KDH3008



Crystal  
D-Handle  
2 KDH3009



Crystal  
D-Handle  
4 KDH3012  
4 KDH3013



Wilton  
Knob Handle  
3 KDH3014

### Timber



Spencer  
Oak Knob  
Handle 1  
S87/44BL  
1 S87/55BL



Spencer  
Light Oak Knob  
Handle 1 S87/44X71



Spencer  
Oak stained &  
lacquered Knob Handle  
1 S87/44X20



Archer  
Sanded Oak Knob  
Handle 1 S87/44X10  
1 S87/55X10



Archer  
Oak Knob  
Handle 1  
S87/44CR  
1 S87/55CR



Hampstead  
Walnut & Matt Black  
Knob Handle  
3 K1126.30.WAMB



Hampstead  
Walnut & Brushed  
Brass Knob Handle  
3 K1126.30.WABHB



Hampstead  
Walnut & Matt Black  
Bar Handle  
5 H1165.160.WASMB



Hampstead  
Walnut & Brushed  
Brass Bar Handle  
5 H1165.160.WABHB

## PUSH LATCH



Hidden Push Latch  
Mechanism for handleless  
frontals 1 KDH3039

PRICE BANDS  
1 2 3 4 5





# Lighting

COLLECTION

From spotlights to illuminate your wardrobe internals, to strip lighting to showcase your organised shelves, our lighting collection will help you to create the perfect mood in your bedroom or home office and make any scheme feel lighter and brighter.

# LIGHTING



## STANDARD CHIP ON BOARD (COB) TAPE LIGHTS

- Chip On Board (COB) lights are the latest innovation in home lighting.
- 360 individual LED's per metre are used to create a seamless, uniform finish
- Very High Bond tape allows for quick, secure installation
- 4W per metre
- IP20 rating
- Cut marks every 25mm means a high quality and professional finish is easily achievable in a fraction of the time
- 2M distributor cable attached to each end for easy fitting directly to drivers



**Natural White Kit**  
SY6019NW

Kit includes 5M natural white COB reel and 20W driver and reconnection cable

**Natural White**  
SY9018A/NW

5M natural white COB reel



**Warm White Kit**  
SY6019WW

Kit includes 5M warm white COB reel, 20W driver and reconnection cable

**Warm White**  
SY9018A/WW

5M warm white COB reel

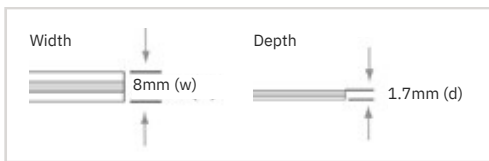

## STANDARD CHIP ON BOARD ACCESSORIES



SY9002  
1.5M reconnection distribution cable to allow standard COB cut-strips to be re-used



SY9023  
Direct connector (to join cut ends of standard COB strip together)



SY9024  
30mm flexible connector for standard COB strip



SY9025  
L shaped standard COB corner connector

## ALUMINIUM RECESSED PROFILES

Mounting an LED strip light within an extrusion not only helps to keep runs straight and neat, it also assists with heat dissipation which prolongs its life.

The included diffusers complete the clean look, and provide protection from dust.

SY7388A

1M profile including end caps

SY7392A/2.5

2.5M profile including end caps



## ROUND UNDER CABINET LIGHTS

- Easy surface mounting with magnetic installation



**Natural White**  
SY8944

3 x round natural white  
2W lights and 8W driver

**Warm White**  
SY8944WW

3 x round warm white  
2W lights and 8W driver

**Natural White**  
SY8935A

Single round natural  
white 2W light

**Warm White**  
SY8935A/WW

Single round warm  
white 2W light



Dimensions (mm)

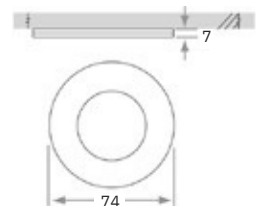

# EVOLINE



## BACKFLIP

The Evoline BackFlip sits nearly flush on a surface. At a touch of a finger, it turns 180 degrees to reveal two power sockets and a USB charger. With a total installation height of just 53mm, the BackFlip can be fitted above most drawers. Perfect to use on custom desks.



**Black Glass (Gloss)**  
BBF2BK



**Stainless Steel**  
BBF2SS



**White Glass (Gloss)**  
BBF2WH



# DECORATIVE LEGS

## Beech Varnished Leg

BDL150BE

Size: 150mm



## Chrome Stackable Feet

BSF80BC

Size: 60x80x64mm

Finish: bright chrome



## Chrome Decorative Leg

BDL120CH

Size: 120mm, flat base

Finish: bright chrome



## Black Mounted Frame

BMODF430BK

Size: 150x430x40



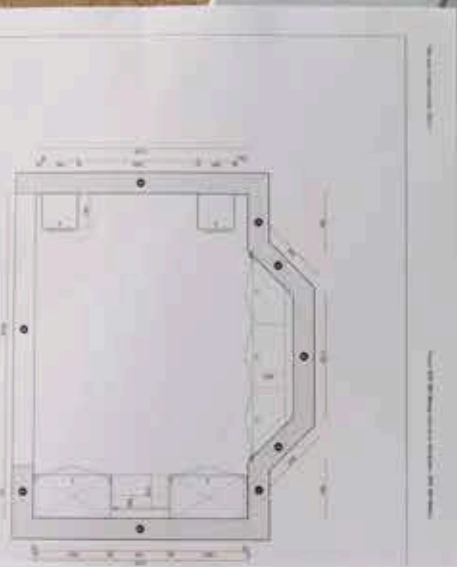

# Planning & Guidance

Here you will find advice on how to plan and design your dream bedroom or home office.

Should you need any further advice, your sales advisor will be able to talk you through your vision and guide you on everything that's possible in your space.

Hinged	15
Made-to-Measure	2
Sliding	15
	4
	15
	6

# HINGED

## HOW TO PLAN FOR YOUR HINGED WARDROBES

### Step 1. Measure your space

Ensure you are fully equipped to start planning. Measure your space wall to wall, and include ceiling heights.

Remember to note:

- 3 Sockets
- 3 Radiators
- 3 Switches
- 3 Doors
- 3 Window ledges

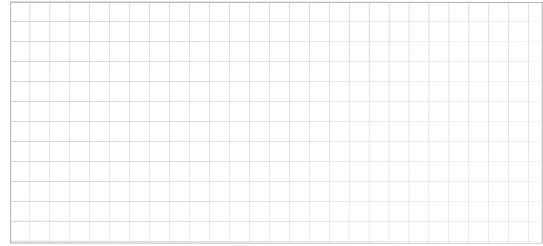

### Step 2. Create a wardrobe run

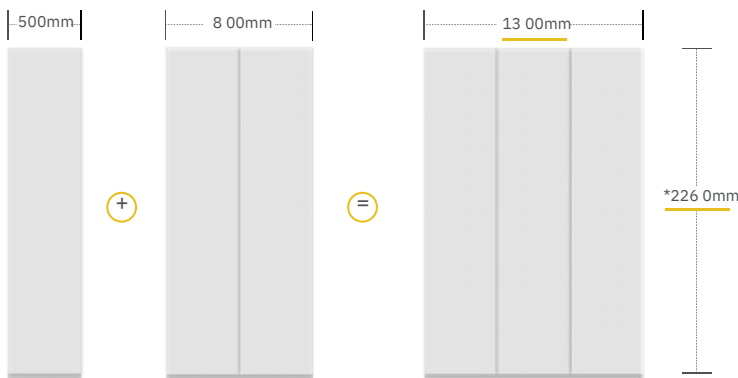

Get an idea of the wardrobe you want by adding combinations together.

### Step 3. Add end panels/fillers or posts

Depending on whether your design is wall to wall or open ended, you will need to add either an end panel or a custom fit plinth as a filler to cover the linen coloured cabinet.

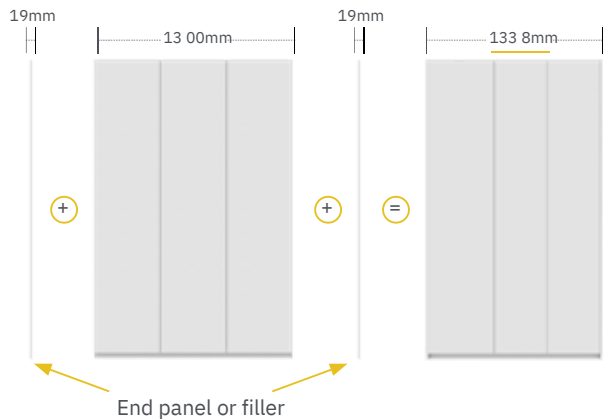



## Step 4. Add cornice and plinth

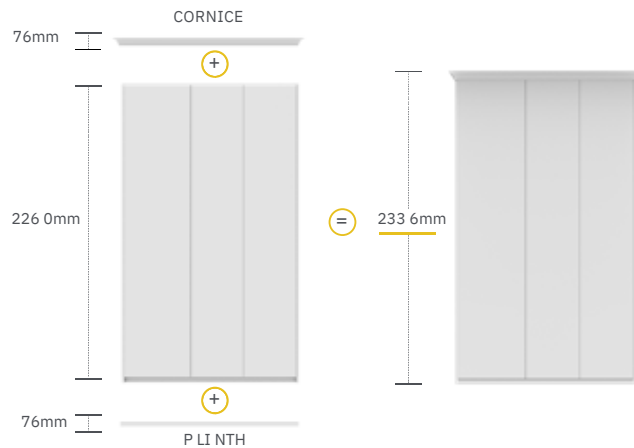

You will always need to use a length of plinth to cover the structural base of the wardrobe and depending on whether your design has the space, you can either add a cornice or ceiling infill, to complete the wardrobe look.

## Step 5. Add your internal storage

We have multiple internal storage options for our wardrobes. You can choose from pre-determined bundles or create and design your own.

See page 76 to view our entire internal storage collection.



# MADE-TO-MEASURE

## HOW TO PLAN FOR YOUR HINGED WARDROBES

### Step 1. Measure your space

Ensure you are fully equipped to start planning. Measure your space wall to wall, including ceiling heights.

Remember to note:

- 3 Sockets
- 3 Radiators
- 3 Switches
- 3 Doors
- 3 Window ledges

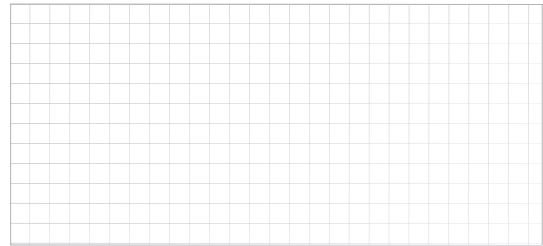

### Step 2. How many doors

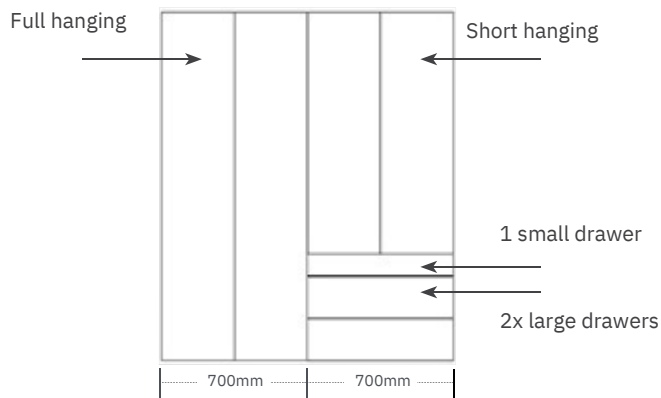

Measurements can help give you an idea of the wardrobe storage you can have by drawing out how many drawers and doors you require.

### Step 3. Add end panels/fillers or posts

Decide if you want to include end panels, fillers or posts on your wardrobes or whether you would like a decorative cabinet

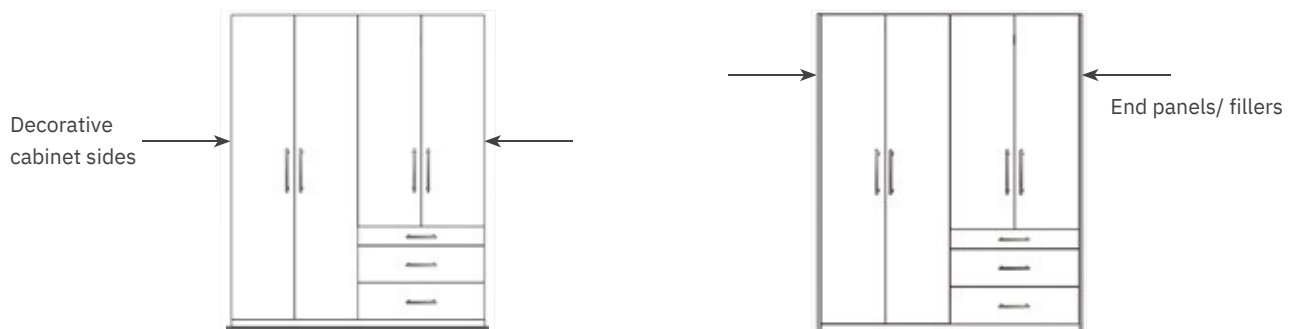

## Step 4. Height

---

Decide what height you would like your storage to be

Wardrobes right to the ceiling ↓



Wardrobes with space above ↓



## Step 5. Add your internals

---

Depending on your storage needs, design your own internals.



# MADE-TO-MEASURE / SLIDING

## HOW TO PLAN FOR YOUR SLIDING WARDROBES

### Step 1. Measure your space

Ensure you are fully equipped to start planning. Measure your space wall to wall, including ceiling heights.

Remember to note:

- 3 Sockets 3 Radiators
- 3 Switches 3 Doors
- 3 Window ledges

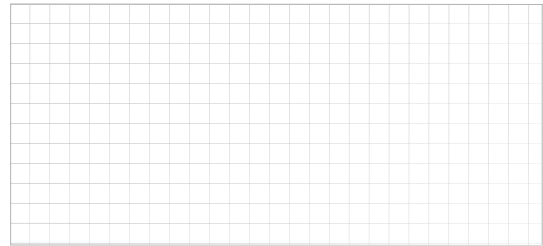

### Step 2. Create a wardrobe run

**Decide how many doors you would like for your run.**

**Whether its 2, 3 or 4.**

*Please keep in mind if you are using internal storage how this would work with the number of doors you require.*

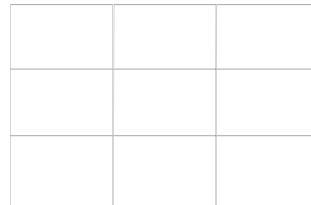

### Step 3. Choose your Aluminium frame profile

The look you are aiming to achieve with your sliding wardrobe will depend on the frame option. We have 3 frame types and 6 frame colours to choose from; some may be easier for you to open than others as each frame type has a different shape.

*Its best that you take the time to select the frame that is best for you, as once selected it cannot be changed.*

#### FRAME OPTIONS



CURVE

CUBE

SHAPE

Curve is for glass door use only

#### FRAME PROFILE COLOUR



SATIN SILVER

WHITE GLOSS

BLACK GLOSS

CHAMPAGNE

CASHMERE

MATT BLACK

## Step 4. Choose your door styles

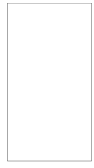

FULL PANEL



EQUAL TWO



LOW 400



CENTRAL 400



EQUAL THREE



WIDE 400



WIDE 300

## Step 5. Choose your door finishes

Choose from over 35 colours across matt and gloss coloured board, woodgrain board, glass, satin glass and mirror.

Whether you would like all one colour or mix of materials, the choice is yours.

### WOODGRAIN BOARD COLOURS BOARD COLOURS



### GLASS COLOURS



### LINEN COLOURS

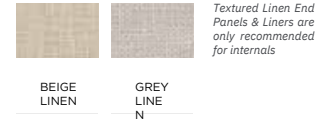

### SATIN GLASS COLOURS

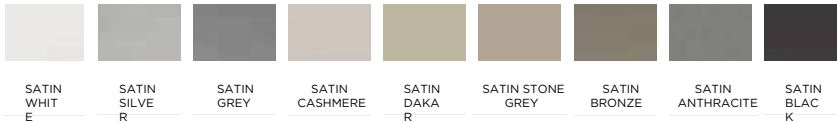

### MIRROR

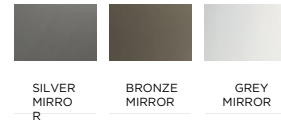

## Step 6. Choose your endpanel and liners

Choose from 15 colours across matt and gloss coloured board, woodgrain and textured board.

Ask your retailer for colour options.



End panel



Liner

## Step 7. Choose your internals

Choose from 12 colours across matt coloured, woodgrain and textured board.

Ask your retailer for colour options.



Shelf & hanging rail

# PORTLAND

## Bedrooms & Home Office — Collection —

### **Colour Reproduction**

We take great care in the photography of products illustrated. Due to variables between photographic and print processes, colours and shades may vary from the actual product supplied.

### **Copyright Notice**

Photographs and images supplied or made available by PWS are copyright works. All rights in them are reserved whether arising under the national laws of any country, any international treaty or convention, or in any other way. The copyright and all other rights in such photographs and images are owned by PWS Distributors Limited. The photographs and images may not be used, reproduced, transmitted, stored in any form or by any means without the prior written permission of PWS Distributors Limited, except as permitted by any law and then only to the extent strictly permitted by such law. PWS Distributors Limited asserts all its rights in or relating to such photographs and images and the copyright in them to the fullest extent possible in all parts of the world. (c) PWS Distributors Limited.



This publication is printed on materials from well-managed forests and is a paper for which the production and distribution has been carbon balanced by The World Land Trust.



WORLD  
LAND  
TRUST™

[www.carbonbalancedprint.com](http://www.carbonbalancedprint.com)  
CBP2105



# PORTLAND

[design@portlandcollective.co.uk](mailto:design@portlandcollective.co.uk)

Bedrooms &  
Home Office  
— Collection —